

Product Code: OVMD9014

Description: 100W Dual Mode LED dimmer Module

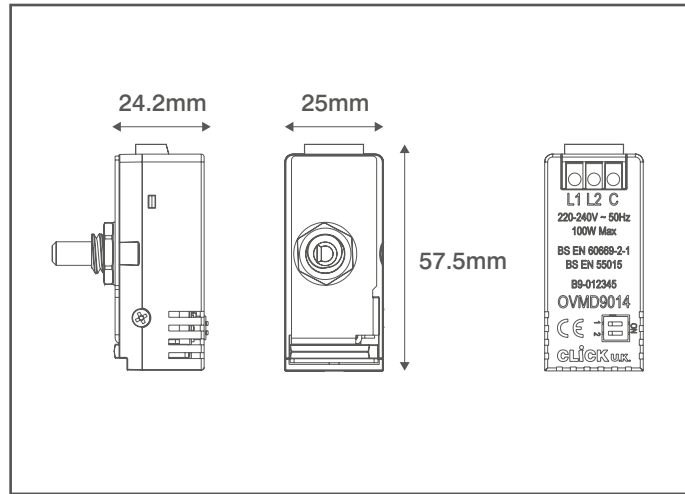

General Information

Dimensions	25mm (W) x 57.5mm (H) x 23.64mm (D)
Materials	Housing: Nylon
Product Weight	0.036Kg
Aperture Required	M10
Type	Leading Edge Technology / Trailing Edge Technology
Warranty	1 Year

Supply & Power

Input Voltage & Frequency	220-240V ~ 50Hz
Minimum Load	5W
Maximum Load	100W
Suitable Loads	Resistive, Inductive & Capacitive
Ambient Temperature (Ta)	-5°C - +45°C
Cable Size	2 x 1.5mm ²

Overview

Dual Mode	The dual mode switching offers the facility to dim LED light sources which utilize either leading edge or trailing edge technology.
-----------	---

Additional Information

The dimmer is pre-set to trailing edge mode with trailing edge most suitable for current types of lighting which includes dimmable LED's.

Some lighting loads which includes some type of LED's perform better using leading edge mode. The dimmer can simply switch between trailing edge and leading edge via the dip switches on the back of the dimmer.

The dimmer also offers the facility to set the minimum brightness using a second dip switch.

Ensure that the mains supply is isolated before commencing installation and refer to the circuit diagram supplied with the relevant product.

We DO NOT recommend mixing different load types on the same dimmer switch / circuit

